

## Research Article

# A Low-intensity Laser Control System Design

Yuhui Cheng, Fengzhi Dai

*Tianjin University of Science and Technology, 300222, China*

## ARTICLE INFO

*Article History*

Received 22 November 2021

Accepted 21 April 2022

*Keywords*

Single chip microcomputer

Laser

Pulse width modulation

Power failure protection

## ABSTRACT

Low-power laser therapy is widely used in the treatment of various diseases as a clinical adjuvant therapy. In this paper, a multi-channel low-power laser physiotherapy equipment design scheme is proposed. The laser exciter used in this scheme can generate laser light with a wavelength of  $650\pm 20\text{nm}$ . In order to realize the requirement of multi-point irradiation, the device has designed 8 laser channels, and these channels are controlled by the main control unit composed of STM32F407ZGT6 single-chip microcomputer. The user can control the power, frequency and working time of the laser generator only by making some simple settings on the operation unit. In order to ensure the integrity of the treatment process, the system has designed a power-off protection mechanism, which can automatically save the working parameters in progress.

© 2022 *The Author*. Published by [Sugisaka Masanori](#) at ALife Robotics Corporation Ltd  
This is an open access article distributed under the CC BY-NC 4.0 license  
(<http://creativecommons.org/licenses/by-nc/4.0/>).

## 1. Introduction

As a non-invasive treatment plan, low level laser therapy is widely used in the treatment of skin lesions, joint lesions, vascular lesions and other diseases. It acts on the human body by emitting a single wavelength of laser light to produce a series of biological stimulation responses, thereby regulating the physiological state of the human immune system, nervous system, blood circulation system and tissue metabolism system. In the application experiments in recent years, numerous treatment cases and experimental data have shown that the program can play a good role in specific diseases[1]. This treatment has many advantages, such as non-invasive, short treatment time and low risk[2]. These characteristics make laser physiotherapy technology very popular.

Low-intensity laser physiotherapy equipment has high requirements for performance, especially the accuracy of control signals. It also requires products with good safety and reliability. In terms of function, for different needs, different laser sources are needed for treatment. How to control multiple laser generators to work together at the same time is a difficult point.

Corresponding author's E-mail: [daifz@tust.edu.cn](mailto:daifz@tust.edu.cn) web: [www.tust.edu.cn](http://www.tust.edu.cn)

Based on the above discussion, this design is optimized for the precise control of multiple light sources. The design of laser physiotherapy apparatus proposed in this article can control eight laser generators to work at the same time.

As a medical auxiliary device, safety and stability are factors that must be considered. In order to ensure the reliability of the system, an emergency stop mode and a power-off protection mechanism are designed in this paper. If an unexpected situation occurs during the treatment, the operator can quickly turn off the equipment to stop the output through the emergency stop mode, and at the same time, in order to avoid the loss of the set parameters after the emergency power off. When the device is powered on again, the power-off protection mechanism will automatically restore the device to the state before the power-off.

## 2. The Hardware Structure

The final control effect achieved by the laser controller is closely related to each functional module. According to the hardware structure, the laser physiotherapy instrument can

be divided into the following three parts: operation unit, control unit and working unit, which is shown in Fig 1.

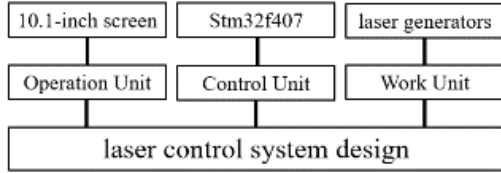

Fig.1 System structure diagram

The operation unit is an important part of the system to realize human-computer interaction. The unit consists of a 10.1-inch touch screen and an emergency stop button. The main control unit, buzzer and power module are integrated into a PCB circuit board, and the processing of the received signal and the output of the control signal will be completed in this part.

The PCB board is designed to reduce circuit complexity and improve the practicability of the device. For a qualified product, the PCB design can directly affect its performance. The design of the PCB board is shown in Fig.2.

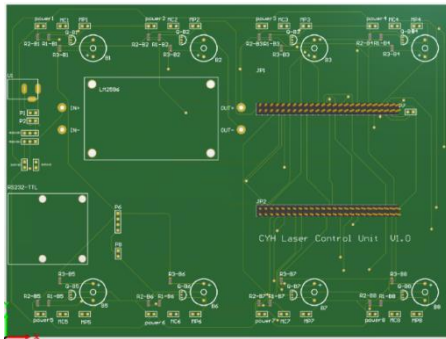

Fig.2. The designed PCB board

### 2.1. Capacitive touch screen

The DWIN serial capacitive touch screen is used as the data input terminal. Its creen resolution is 1024\*600 pixels, and the ideal working power supply is 12V, 1A. The operating temperature is between -20°C and 70°C. The DWIN capacitive touch screen is shown in Fig.3.



Fig.3. Front and back of the DWIN screen

The screen supports RS232 and TTL two serial port modes for communication, and its corresponding working voltages are 12V and 5V respectively. In order to match the working voltage of the single-chip microcomputer, the TTL communication mechanism is adopted in this design. The communication data format is 16-bit hexadecimal characters, and the data format is shown in Fig.4.

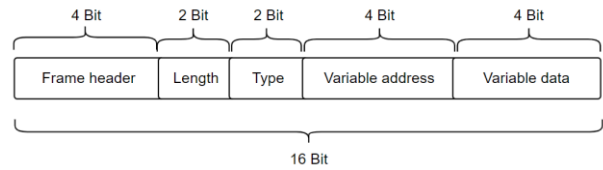

Fig.4. Serial communication data format

### 2.2. Eemergency module

The electrical safety of the equipment is considered at the beginning of the design of this system. In addition to the optimization of the circuit design part, the system also designs an emergency stop mechanism for potentially dangerous situations. Through the emergency stop button, the operator can cut off the power supply of the power unit in time to avoid the occurrence of unexpected situations.

In order to obtain the status information of the emergency stop button control circuit, this design connects the ground terminal interface to the IO port of the single-chip microcomputer. The power supply line end interface is connected to the working unit. The emergency stop button is shown in Fig.5.



Fig.5. Emergency button

### 2.3. Main control unit

The main control unit includes a control chip, a power supply circuit and a signal output interface. The control chip model is STM32F407ZGT6. The chip adopts a 32-bit Cortex-M4 CPU with FPU, the main frequency is up to 168MHz, and it is equipped with 140 IO ports with terminal functions. The chip has 1MB of Flash memory and 192+4KB RAM. The equipped 17 timers can well meet the requirement of multi-channel PWM signal output[3]. Other related features are as follows:

- Up to 15 communication interfaces, including 6x USARTs running at up to 11.25 Mbit/s, 3x SPI running at up to 45 Mbit/s, 3x I<sup>2</sup>C, 2x CAN, SDIO
- Analog: two 12-bit DACs, three 12-bit ADCs reaching 2.4 MSPS or 7.2 MSPS in interleaved mode
- Operating Voltage 2.0V ~ 3.6V.
- Operating temperature range: -40 °C ~ 105 °C.

The design of the main control chip is shown in Fig.6.



Fig.6. STM32F407ZGT6 chip

### 2.4. Working unit

The working unit is composed of a laser drive module and a laser module. The laser drive module is shown in Fig.7.

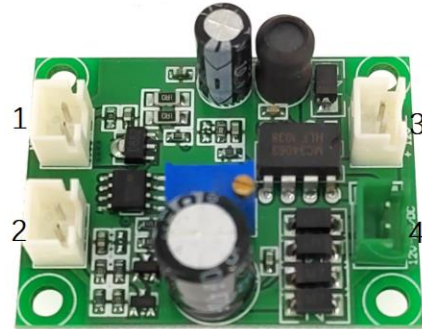

Fig.7. Laser drive module

The laser is essentially a current-mode device. Whether the laser device emits light is related to the on-off of the current. The luminous intensity of the laser device is proportional to the current intensity within the working range of the laser. The laser drive module actually modulates the input electrical signal and converts it into a series of characteristics of the laser light. The laser driver module has four interfaces, the interface 1 is the laser output terminal, the interface 2 is the signal input terminal, and the interfaces 3 and 4 are the power ports. By controlling the signal input of the laser drive module, the power and frequency of the laser output can be adjusted.

The wavelength of the laser source used in this design is 650±20nm. Lasers of this wavelength can stimulate the subcutaneous tissue of the human body through the epidermis and dermis of human tissue. Its working parameters are as follows:

- Operating temperature range: -10 °C ~ 50°C.
- Operating voltage: 10~12V
- Operating current: <200mA
- Laser Safety: Class IIIB

The laser generation module is shown in Fig.8.



Fig.8. Laser generation module

### 3. System Circuit Module Design

This system adopts the STM32407ZGT6 core board, which is equipped with the smallest circuit system of single-chip microcomputer and the download and debug interface.

Therefore, when designing the circuit, only need to consider the signal output interface circuit, voltage conversion circuit and buzzer drive circuit. This kind of scheme is more convenient in design, so as to realize the design of PCB quickly.

#### 3.1. Voltage conversion circuit design

The voltage conversion circuit converts the 12V DC input from the power adapter into 5V DC through the LM2596 module.

LM2596 is a switch type step-down chip, usually is a step-down circuit with a constant voltage output. The chip samples the output voltage value through a resistor and inputs to the chip's feedback terminal. The output voltage can be changed by changing the resistance of the resistor. The schematic diagram of the power circuit design is shown in Fig 9.

Formula (1) is to calculate the  $V_{ref}$ . The value of  $R_1$  in this circuit is fixed at  $2.5K\Omega$ , and the value of  $R_2$  is determined by the chip model. When the output voltage  $V_o$  is 5V, the resistance value of  $R_2$  is  $7.6K\Omega$ , then the reference voltage  $V_{ref}$  is 1.24V.

$$V_{ref} = V_o * R_1 / (R_1 + R_2) \quad (1)$$

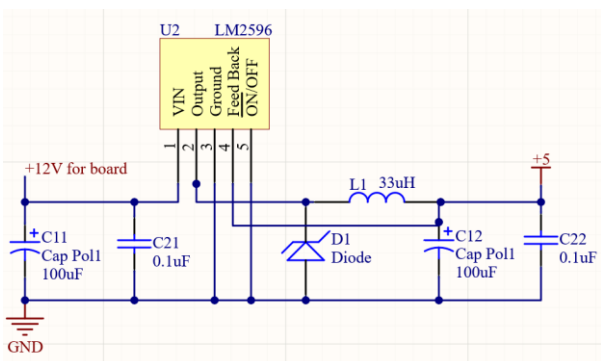

Fig.9. Schematic diagram of the power circuit

#### 3.2. Design of buzzer drive circuit

For an active buzzer, the only thing to do is to input the drive level at the signal end and amplify the drive current through a transistor to make a sound.

Through the test, the actual working time of the buzzer is about 4.7V, and the working current is 30mA.

The schematic diagram of the buzzer drive circuit is shown in Fig.10. In the circuit,  $R_1$  and  $R_3$  play a current limiting role, and  $R_2$  is a pull-down resistor, which can improve the turn-off speed of the transistor.

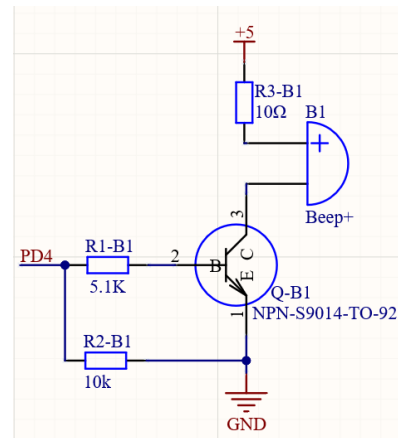

Fig.10. Schematic diagram of the buzzer drive circuit

### 4. The Functional Module

The physical architecture of this system is composed of the various hardware modules introduced earlier, and these modules complete the most basic functions. As a control system, how to design a brief and smooth software architecture is the key point for the entire system to accomplish the set goals.

In line with the purpose of reliability and convenience, the operation process is simplified as much as possible in this design. After the system is powered on, the device starts and displays the initial interface on the interactive interface. After confirming to enter the system, the system has designed a buffer time of 3 seconds, and you can enter the preparation interface after the countdown is over. In this interface, you can view the parameters of each laser channel set before, including power, frequency and running time. After confirming the setting information,

you can enter the working interface, set the parameters of each channel, and start the laser.

During the working period of the system, all parameters of the current operation will be saved at any time to avoid data loss caused by unexpected situations. When the working time of the channel reaches the set value, the system will prompt the operator through the buzzer and close the corresponding laser channel at the same time. The system work flow chart is shown in Fig.11.

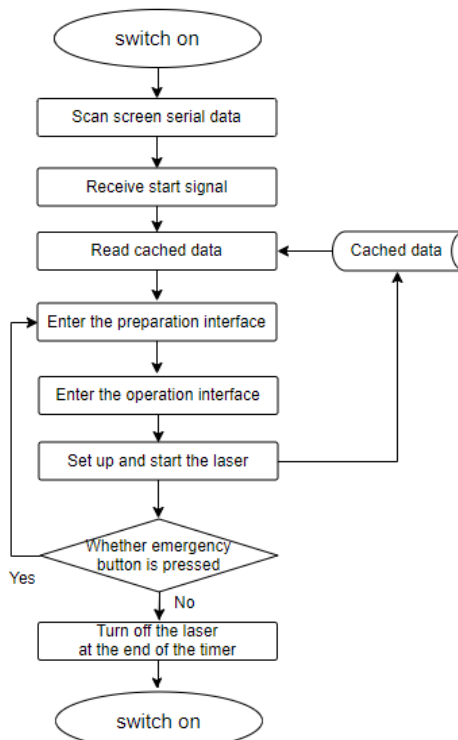

Fig.11. System work flow chart

## 5. Conclusion

Through testing, it can be concluded that this design can complete the work of controlling eight laser generators at the same time. In continuous mode, four-speed power adjustment can be achieved. In the pulse mode, the default working time is 30 minutes, and each laser generator has a separate timing channel, which can realize the time setting of 0-99 minutes. The default laser power is 50%, and the adjustable range of power is 0~100%. The default laser frequency is 50Hz, and the adjustable range is 1~1K Hz.

When an emergency stop is needed, the emergency stop module can also respond quickly and save data.

## References

1. Moskvin SV, Agasarov LG. Laser Acupuncture: 35 Years of Successful Application in Russia (Narrative Review). *Journal of lasers in medical sciences vol.* 2020,11: pp.381-389.
2. Tony Y. Chon, Molly J. Mallory, et al., Laser Acupuncture: A Concise Review, *Medical Acupuncture.* 2019,6: pp.164-168.
3. Cui Lin, Zhu Lei, Bai Lu. Design of PWM waveform generator with adjustable parameters based on STM32 (in Chinese). *Information and Communication,* 2018, 1: pp.129-131.

---

## Authors Introduction

Mr. Yuhui Cheng



He received his Bachelor's degree from the Internet of Things Engineering, Tianjin University of Science and Technology, China in 2019. He is currently studying for a master's degree in electronic information at Tianjin University of Science and Technology.

Dr. Fengzhi Dai



He received an M.E. and Doctor of Engineering (PhD) from the Beijing Institute of Technology, China in 1998 and Oita University, Japan in 2004 respectively. His main research interests are artificial intelligence, pattern recognition and robotics. He worked in National Institute of Technology, Matsue College, Japan from 2003 to 2009. Since October 2009, he has been the staff in Tianjin University of Science and Technology, China.

---